

Technical data sheet for  
**ELECTRIC SALAMANDER**  
E91B

- Powerful 6kW infra-red elements
- Left and right heat control
- Branding plate option
- Wall mounting bracket
- Easy clean
- Easy service



E91B

**Overall Construction**

- Monocoque construction
- Enamelled front brow
- External panels of 0.9mm 304 grade stainless steel
- Stainless steel tray under grilling area with grease trough
- Two 3kW infra-red elements

**Racking**

- Four position racking (flat or inclined)

**Controls**

- Large easy use controls
- Heat resistant reinforced control knobs
- Indicator light for each element
- Each side controlled by a 3 heat switch

**Cleaning and Servicing**

- Access to all parts from front of unit
- Stainless steel and enamelled surfaces used throughout

# Technical data sheet for **ELECTRIC SALAMANDER**

## Specifications

**Elements**  
2 x 3kW

**Electrical requirements**  
230-240V, 1P+N+E, 50/60Hz, 6kW, 25A

**Dimensions**  
Width 900mm  
Depth 424mm (455mm with wall mounting bracket)  
Height 456mm

**Cooking area**  
Rack size 610mm x 310mm, 1890cm<sup>2</sup>  
Branding Plate 610mm x 310mm, 1890cm<sup>2</sup>

**Nett weight**  
36kg

**Packing data**  
0.31m<sup>3</sup>, 63kg  
Width 945mm  
Depth 520mm  
Height 635mm

**Electrical connection**  
230-240V 1 phase hard wired via terminal block at back of unit 64mm from right side and 90mm from bottom of unit

**Options**  
100mm high feet for bench mounting

E91B

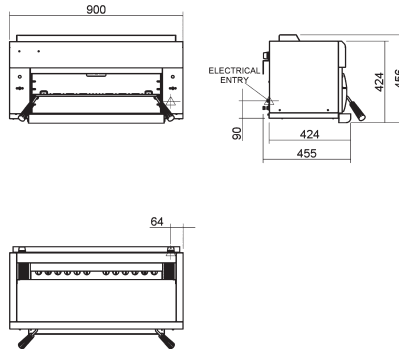

**BLUE SEAL**  
EVOLUTIONSERIES

**BLUE SEAL**

[www.blueseal.co.uk](http://www.blueseal.co.uk)  
[www.bluesealevolution.com](http://www.bluesealevolution.com)

## United Kingdom Blue Seal Limited

Unit 67  
Gravelly Business Park  
Gravelly  
Birmingham B24 8TQ  
England  
Telephone 0121-327 5575  
Facsimile 0121-327 9711  
Email [sales@blue-seal.co.uk](mailto:sales@blue-seal.co.uk)  
[www.blue-seal.co.uk](http://www.blue-seal.co.uk)

## Australia Moffat Pty Limited

740 Springvale Rd  
Mulgrave  
Victoria 3170  
Australia  
Telephone 03-9518 3888  
Facsimile 03-9518 3833  
Email [vsales@moffat.com.au](mailto:vsales@moffat.com.au)  
[www.moffat.com.au](http://www.moffat.com.au)

## New Zealand Moffat Limited

16 Osborne St  
PO Box 10-001  
Christchurch 8011  
New Zealand  
Telephone 03-389 1007  
Facsimile 03-389 1276  
Email [sales@moffat.co.nz](mailto:sales@moffat.co.nz)  
[www.moffat.co.nz](http://www.moffat.co.nz)



Designed and manufactured by

**MOFFAT**

ISO9001  
All Blue Seal products are designed and manufactured by Moffat using the internationally recognised ISO9001 quality management system, covering design, manufacture and final inspection, ensuring consistent high quality at all times.

**CE**

In line with policy to continually develop and improve its products, Moffat Limited reserves the right to change specifications and design without notice.

Printed in China  
© Copyright Moffat Ltd  
Moffat/4825-UK/BH/2.5M/12.06

